

Display-Metrology & Systems

Standards and Metrology for Reflective LCDs

Michael E. Becker

Abstract

This paper summarizes existing international standards and describes the problems that are currently obstacles in the way to reproducible metrology for reflective LCDs. Identification and removal of these problems shall help establishing a well founded and reasonably applicable international standard for reflective LCD-metrology. We present a simple concept for detailed characterization of the illumination conditions and introduce a compact new device that supports the required measurements with the due flexibility in illumination geometry, with the required robustness and reproducibility.

1 LCD-Metrology Standards

After many years of cooperative and constructive discussions, simple approaches to measuring LCDs have been standardized by the IEC SC47C/WG2 in the framework of IEC 61747 "Liquid crystal and solid-state display devices". This standard comprises the following sections: Generic, Sectional and Blank Detail Specifications, Visual Inspection, Environmental Endurance Test, Terminology and Letter Symbols, Essential Ratings and Characteristics, and finally the "Measuring Methods". This document however is restricted to transmissive LCDs. The IEC TC 100 has additionally generated the standard IEC 61966-4: "Colour Measurement and Management, Part 4: Equipment using LCD panels" describing a metrology for electro-optic and electro-colorimetric characteristics, lateral variations of luminance and chromaticity, variations of luminance and chromaticity with viewing-direction for transmissive LCDs.

The terms and definitions used by these two IEC standards unfortunately are not synchronized, and the measurement methods exhibit differences, a fact that is disturbing and confusing for the user.

The VESA FPDM standard, even though not explicitly addressing the subject of reflective LCDs, is a most valuable resource for all aspects of well-founded display metrology in theory and application (including various approaches to reflectance evaluation), and it surely is the most comprehensive and qualified text on the subject currently available.

More than 26 years after description of the first measuring system for reflective LCDs by G. G. Barna, however, still no approved international standard is available as a basis for objective and comparable evaluation of the electro-optical and visual properties of this type of display.

1.1 Metrology for reflective LCDs

Especially in the case of reflective LCDs it is hard to achieve the required unambiguity and reproducibility of the results because of the close coupling between the measuring apparatus (illumination and receiver) and the display to be measured. This dependence of the results on instrumentation implies that e.g. the contrast of reflective LCDs and its variation with viewing-direction is not an intrinsic property of the device itself. It becomes a meaningful characteristic only together with the well specified conditions of the measurement apparatus and the procedure. These "conditions to be specified" have to be clearly identified in the standard.

Display-Metrology & Systems

The problems related to measuring the electro-optical properties of reflective LCDs have been known since the early attempts to characterize and optimize the variations of LCD-contrast with viewing-direction. A first method for illuminating reflective LCDs during the measurement with a glass-hemisphere producing a multidirectional "diffuse" illumination was proposed by Barna in 1976 and realized in a commercial product in Germany starting in 1985. Parallel to this another goniometric approach was implemented in Japan and later on fixed in a national standard of the EIAJ (ED-2523 MM Reflective LCDs). The latter method uses a directed beam source out of the specular direction of the receiver, with the effect that variations of the optical properties of LCDs with viewing-direction cannot be measured in a reasonable way. It is obvious that both approaches make use of two extreme illumination situations: multi-directional "diffuse" and directed beam illumination, but the results obtained are still subject to superficial comparison and to commercial interests, since often the conditions under which the "numbers" listed in the data sheet have been generated are not known nor are the respective consequences and implications understood.

The reasons for the large differences in the results that are obtained with these two approaches in the case of reflective LCDs have been analyzed in detail and the results are published in a series of papers. There it could be shown that the intrinsic variations of contrast with viewing-direction, known e.g. from transmissive measurements, can only be reproduced in the reflective mode of operation under multi-directional ("diffuse") illumination.

The basic reference to the subject of measurement and evaluation of reflectance characteristics in general is provided by the CIE publication No. 38 (1977), a highly valuable guideline that seems to be unknown to many authors that work on and publish about the subject of reflective displays.

One important task for all standardization committees that are focusing on electronic display devices in various organizations (IEC, ISO, CIE, etc.) is the synchronization of terms and definitions and basic measurement procedures for that field in order to remove the confusion currently caused by the diversity of existing standards.

1.2 Metrology Standard for reflective LCDs

These days finally there is a move to establish the optical metrology for reflective LCDs in an international standard (WG2 of IEC/TC47C). This standard is supposed to cover the needs of display manufacturers in their research and development as well as the requirements of the engineers that are integrating displays into electronic devices (not to forget the purchasing department). The standard shall provide:

- ◆ approaches for detailed characterization of the electro-optical properties of the sample LCD versus viewing-direction (e.g. BRDF and other data as required for subsequent numerical simulation of complex display systems, e.g. spectra),
- ◆ realistic prediction of visual performance under actual illumination conditions,
- ◆ procedures for testing the conformity to product specifications (i.e. acceptance screening),
- ◆ applicability to all kinds of reflective displays,
- ◆ applicability to a wide range of instrumentation (e.g. goniometric, conoscopic),
- ◆ applicability to a wide range of operator skills and laboratory budgets,
- ◆ robustness: easy alignment, low uncertainty and parameter-sensitivity, i.e. good repeatability and reproducibility.

Display-Metrology & Systems

2 Illumination conditions

The analysis of a specific application situation is quite simple for stationary display devices like computer monitors that sit on a desk in a typical office environment. We can check the illumination condition in this case by just “looking through the eyes of the monitor” with an appropriate electronic camera. A typical example for the directional distribution of illumination at an office workplace is shown in Figure 1. The most dominant light sources are the windows (daylight) and the ceiling luminaires. A variation of luminance between 100 cd/m^2 (ceiling areas and floor) and maximum values of 30 kcd/m^2 (windows) is measured. With such an approach and with additional spectral analysis the characteristics of illumination can be characterized in the following terms and quantities:

- ◆ Intensity (e.g. luminance) and spectrum versus direction of light incidence, (θ_i, ϕ_i) ,
- ◆ Temporal characteristics (short and long-term variations) of intensity and spectrum.

This example illustrates that even a simple indoor scenario exhibits a wide dynamic range for the intensity with a directional distribution that is different from case to case and with different sources and spectra (daylight, incandescent lamps, discharge lamps, etc).

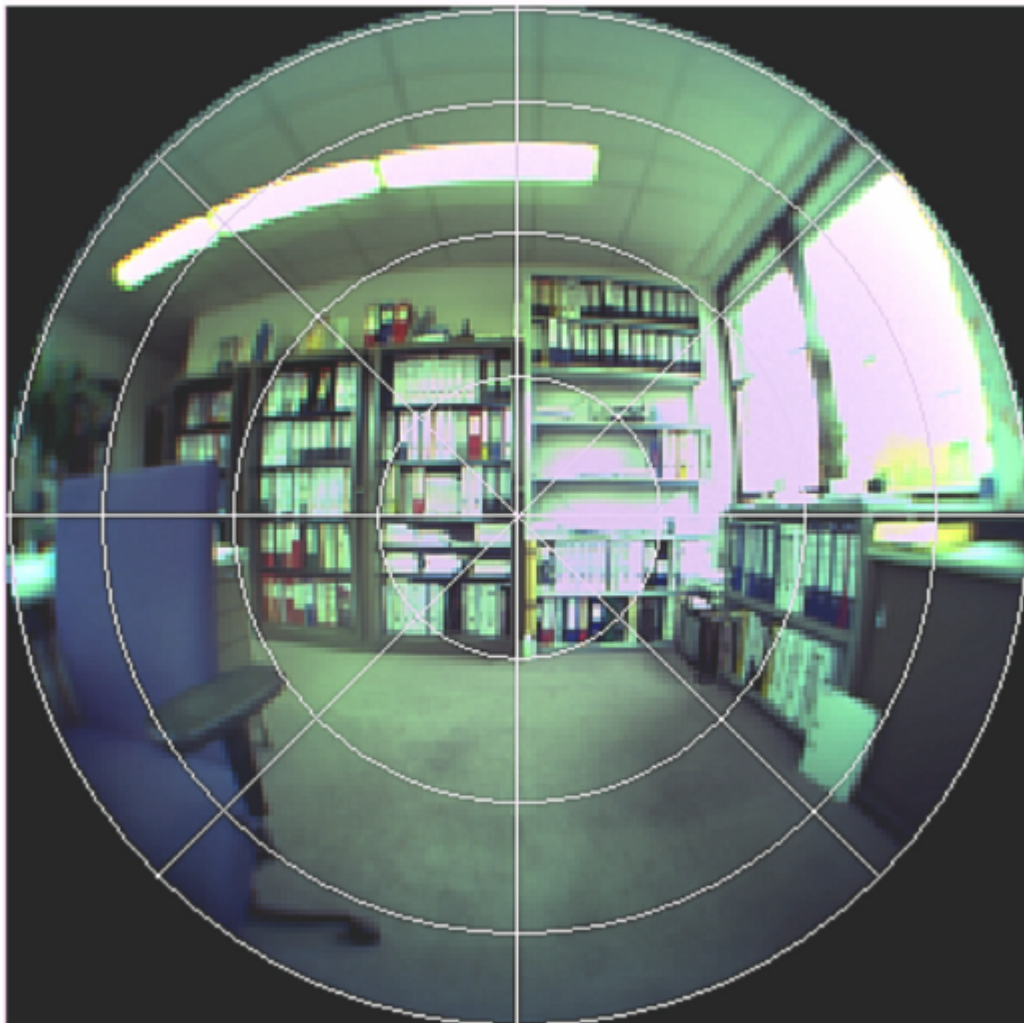

Figure 1: Directional luminance distribution in a typical office as "seen" by a desktop computer monitor, shown in a polar coordinate system (max. inclination $\theta_{\max} = 80^\circ$).

Display-Metrology & Systems

The situation becomes even more variable for portable devices, because neither the orientation of the display with respect to the light sources nor the direction with respect to the user is generally defined. Good performance of displays in portable devices is requested for all locations (indoor, outdoor, clear blue sky, cloudy, etc.) and a range of illumination conditions that is beyond any definition. Since the variety of real-life situations is much too large to extract a single "typical case", we have to consider which special illumination cases might be of interest (depending on the final application of the product), even if they do not occur exactly in reality.

One possibility with distinct advantages for the signal-to-noise ratio of the detector is illumination from a wide range of directions (approximated "diffuse" illumination). This geometry, successfully used in the display industry for more than 20 years, yields lower contrast values than other, non-diffuse illumination schemes but seems to be closer to what we actually see.

The other extreme case is a *directed beam* that illuminates the sample from a given direction within a small solid angle. Suitable choice of the direction of observation (i.e. receiver direction) can produce impressive contrast values in this approach.

This constitutes the current dilemma in reflective display metrology: we may choose between two illumination geometries, one of them providing a high contrast value for a specific viewing-direction (no variations included), the other one yielding moderate contrast values while at the same time allowing for detailed evaluation of variations with viewing-direction.

A compromise is proposed for the standard to come as follows: In a first section, include a limited number of useful configurations with one or more fixed receiver directions, (illumination with e.g. ring-light, directed beam, "diffuse" and "shaped" illumination) and in a second part include other schemes that allow scanning of the viewing-cone for more detailed analysis.

Display-Metrology & Systems

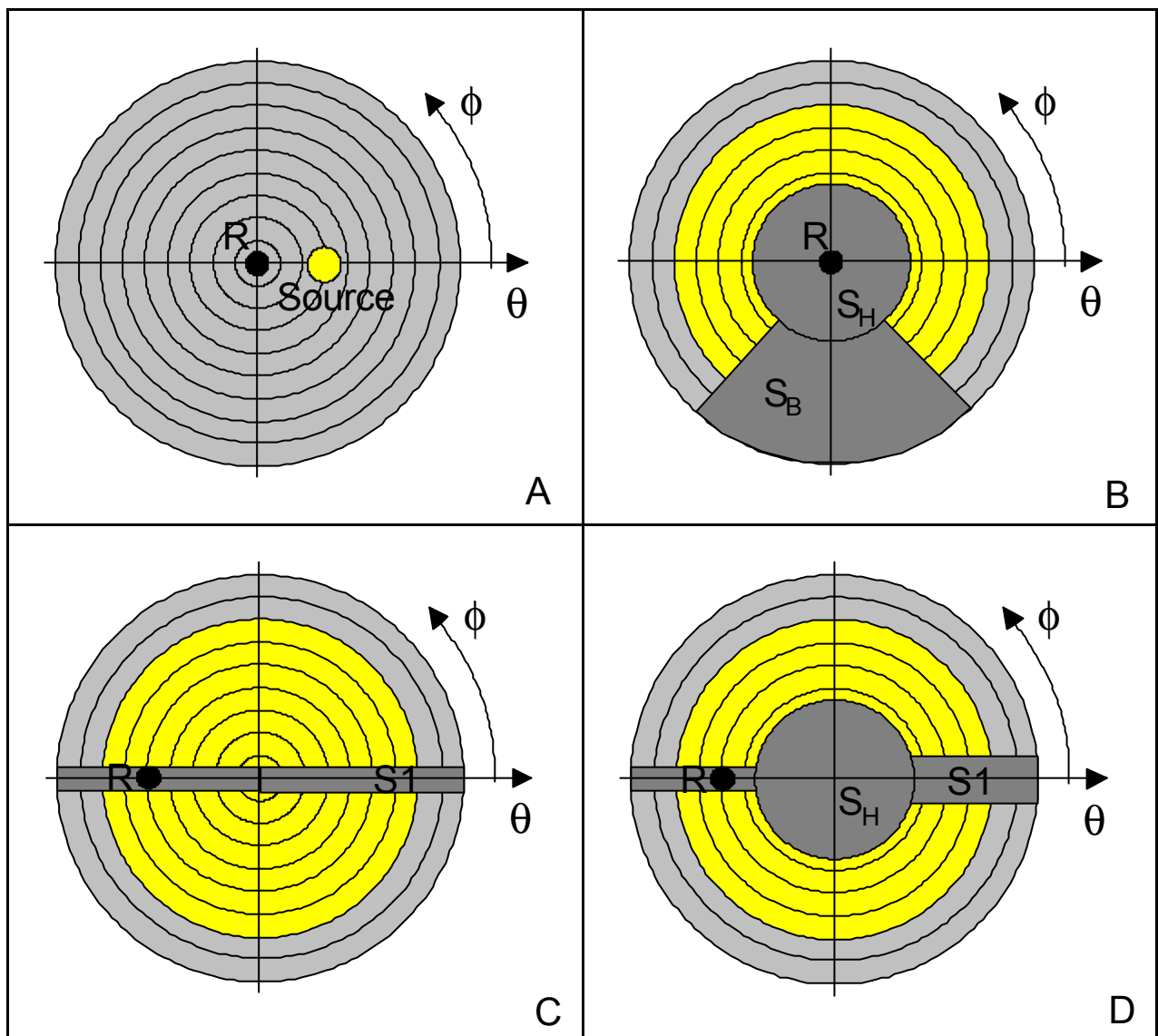

Figure 2: Polar representation of four basic illumination geometries, (A): “directional” illumination at 30° with fixed receiver, R , (B): multi-directional illumination with shoulder/trunk-shade of observer S_B and fixed receiver, (C): multi-directional illumination with shade, S_1 and gloss-trap, (D): multi-directional illumination with head-shade S_H and gloss-trap, both with variable receiver inclination for scanning of the viewing-cone.

2.1 Specification of illumination geometries

In order to enable adaption of the illumination conditions to a wide range of application situations without sacrificing reproducibility, the illumination has to be specified in detail. This is achieved by measurement of the quantities of interest (e.g. luminance, spectra, etc.) at the measuring spot on the sample as a function of the direction of light incidence.

Figure 2 shows the illumination from the perspective of the measuring spot for several typical cases in polar coordinate systems. The sample is illuminated from the directions indicated by bright regions with the dark regions representing shadow (no illumination). Two configurations measure the reflective LCD from fixed but selectable directions (A, B), two other configurations allow scanning of the viewing cone (C, D). Many more combinations of illumination and receiver direction than shown here are possible and allowed as long as they are well specified.

Display-Metrology & Systems

Figures A and B show fixed receivers (normal to the sample) with directional and "diffuse" illumination between 35° and 70° respectively, the latter case approaching an extended ring-light geometry (B). In addition to the shadow cast by the head of the observer, S_H , the shade of shoulders and trunk, S_B , is also included. Here, the receiver is assumed to be in the center of the head. The dimensions of the shade-regions can be adapted according to the distance from display to the observer. Figure C shows "diffuse" illumination up to 70° and a receiver with variable angle of inclination for motorized scanning of the viewing-cone. The slit through which the receiver "looks" at the display extends to the far side of the hemisphere where it acts as a gloss-trap (i.e. suppressing unwanted reflections from the display surface). The width of this gloss-trap can be adjusted to the width of the haze as shown by S_1 in Figure D.

3 Realization

Finally we introduce a flexible concept and device for easy realization of a wide range of different illumination and detection geometries including the above listed cases by modification or complete exchange.

The basic concept is derived from the luminance distribution shown in Figure 1. We can map all light sources in the surroundings of the display into luminance sources on a hemisphere with the measuring spot in its center and realize this arrangement with a dome-construction as shown in Figure 3. The outer dome is the carrier for the light sources and for the receivers while the inner dome is shaping the directional and lateral distribution of light via either scattering translucent material for homogenization of the light distribution or via absorbing material for generation of shadow regions. Clear transparent material is provided for discrete sources and for the receivers. The light sources can be incandescent bulbs, LEDs, circular fluorescent tubes, etc. or light can be supplied from remote sources via lightguiding fibers, thus allowing the combination of light sources with different spectra and intensities.

The dome shown in Figure 3 also carries a multitude of receivers that are "looking" at the measuring spot on the sample from different directions. All receivers are connected to a special multichannel spectrometer with simultaneous fast photometric detection (Multi-SpecTM). The light reflected by the object of measurement is analyzed in terms of luminance and spectral distribution for a multitude of viewing-directions simultaneously. The short time required for one multi-directional spectral measurement makes this device well suited for acceptance screening of a large number of samples and for checking the conformity to product specifications under specific illumination conditions.

Display-Metrology & Systems

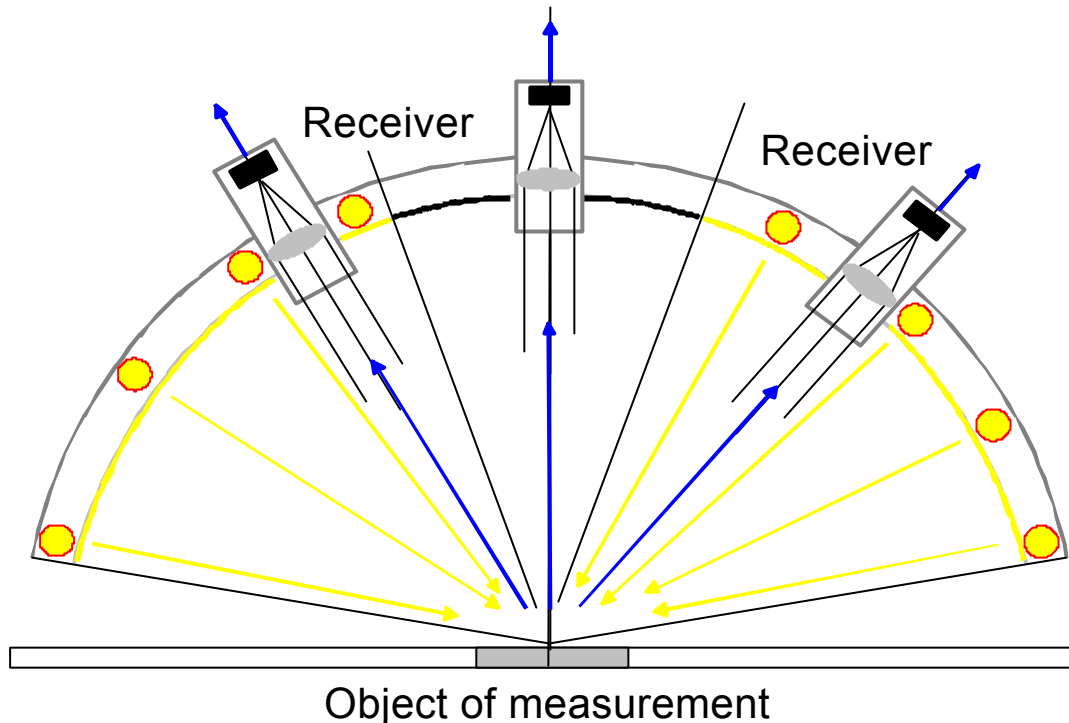

Figure 3: Sketch of the realization of a versatile setup for illumination and detection with a double-layer dome centered around the measuring spot.

4 Conclusion

An international metrology standard for reflective LCDs is supposed to provide unambiguous guidance to the metrologist in the laboratory, to the product-design engineer and to the purchasing department. Besides the clear description of procedures and conditions that are needed to properly take into account the close coupling between the measuring apparatus and the resulting evaluations, it shall not impose unjustified limits to the variety of arrangements and illumination conditions that are required to account for the wide range of applications of reflective displays. Synchronization of all relevant standardization activities with respect to terms and definitions and basic measurement methods remains an important task for the future. We have presented an approach to significant, robust, and feasible metrology for reflective LCDs via detailed specification of the illumination conditions and we have introduced a novel concept for realization of a measuring instrument that can cover a wide range of illumination conditions.